



CITROEN C4 CACTUS  
CITROEN C3 Aircross

09/2014-  
2017 -

Cat. No. C/A43

**E20** E20 55R-01 5265

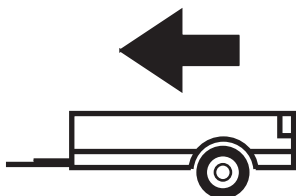

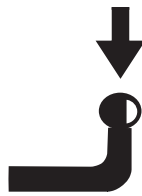

825kg



55kg

**D** = 5,35kN

$$D \text{ (kN)} = \frac{\text{MAX kg} \times \text{MAX kg}}{\text{MAX kg} + \text{MAX kg}} \times 0,00981$$





IMIOLA HAK-POL

96-111 KOWIESY, CHOJNATA 23A, POLAND

Tel. + 48 46 831 73 31, fax +48 831 74 29

e-mail: office@imiola.pl, www.imiola.pl

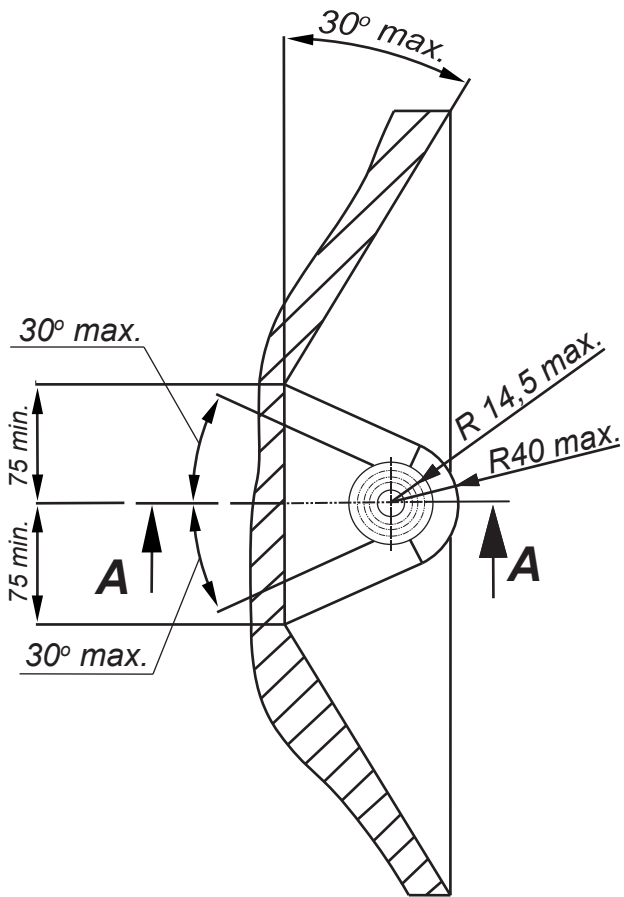

## PRZEKRÓJ A-A

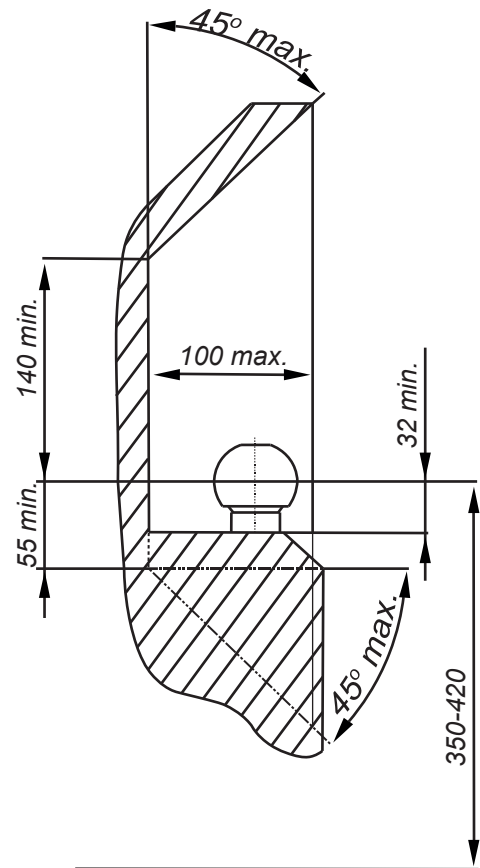

**PL** Należy zagwarantować przestrzeń swobodną według załącznika VII, rysunek 25a/b Regulaminu EKG ONZ 55.01 przy dopuszczalnym ciężarze całkowitym pojazdu.

**F** L'espace libre doit être garanti conformément à l'annexe VII, illustration de la réglementation 55.01 CE pour un poids total en charge autorisé du véhicule.

**GB** The clearance specified in appendix VII, diagram 25a/b of Regulation No. 55.01 UN EU must be guaranteed at laden weight of the vehicle.

**D** Der Freiraum nach Anhang VII, Abbildung 25a/b der Vorschriften 55.01 EG ist zu gewährleisten bei zulässigem Gesamtgewicht des Fahrzeuges.

Moment skracający dla śrub i nakrętek (8.8) Torgue settings for nuts and bolts (8.8)	
M8	25Nm
M10	55Nm
M12	85Nm
M14	135Nm
M16	195Nm







- Odkręcić zderzak .
- Odkręcić dolną śrubę mocującą belkę zderzeniową.
- Odkleić taśmy zakrywające fabryczne otwory w podłużnicach.
- Włożyć Cuget Nut M10 w podłużnice poprzez otwory fabryczne i przykręcić elementy C i D śrubami M10x35 8.8 (pkt 5).
- Belkę haka A przykręcić śrubami M12x40 8.8 (pkt 1) stosując elementy E i F.
- Elementy E i F przykręcić do tylnego pasa śrubami M8x35 8.8 (pkt4).
- Elementy G przykręcić śrubami M10x35 8.8 (pkt2) i śrubami M10x35 8.8 (pkt3).
- Zamontować zderzak.
- Dokręcić wszystkie śruby z momentem według tabeli.
- Dokręcić kulę i blachę gniazda elektrycznego.
- Podłączyć instalację elektryczną.

- Unscrew the bumper.
- The technological holes in the frame side members make permeable.
- Insert Caget Nut M10 in the frame side members through the technological holes.
- Insert the main bar A in the frame side members and screw with bolts M10x35 8.8 (point 1).
- Bended elements screw to the main bar A and to the bottom of frame side members with bolts M10x35 8.8 (point 2 and 3).
- Assemble the bumper.
- Tighten all the bolts according to the torque setting- see the table.
- Fix the ball and electric plate.
- Connect the electric wires.

- Dévissez le pare-chocs.
- Les trous technologiques dans les longerons du cadre rendent perméable.
- Insérer l'écrou Caget M10 dans les longerons du châssis à travers les trous technologiques.
- Insérer la barre principale A dans les longerons du châssis et visser avec les vis M10x35 8.8 (point 1).
- Les éléments pliés se vissent sur la barre principale A et sur le bas des longerons du cadre avec des boulons M10x35 8,8 (points 2 et 3).
- Assembler le pare-chocs.
- Serrez tous les boulons en fonction du réglage du couple - voir le tableau.
- Fixez la boule et la plaque électrique.
- Connectez les fils électriques.

- Schrauben Sie den Stoßfänger ab.
- Die technologischen Löcher in den Rahmenseitenelementen sind durchlässig.
- Setzen Sie die Käfigmutter M10 durch die technologischen Löcher in die Seitenteile des Rahmens ein.
- Setzen Sie die Hauptstange A in die Seitenteile des Rahmens ein und schrauben Sie sie mit den Schrauben M10x35 8.8 (Punkt 1) fest.
- Gebogene Elemente werden mit Schrauben an der Hauptstange A und an der Unterseite der Rahmenseitenelemente angeschraubt M10x35 8.8 (Punkt 2 und 3).
- Montieren Sie den Stoßfänger.
- Ziehen Sie alle Schrauben entsprechend der Drehmomenteinstellung fest - siehe Tabelle.
- Befestigen Sie den Ball und die elektrische Platte.
- Schließen Sie die elektrischen Kabel an.

- Desatornillar el parachoques.
- Los agujeros tecnológicos en los miembros laterales del marco hacen permeable.
- Inserte Caget Nut M10 en los miembros laterales del marco a través de los agujeros tecnológicos.
- Inserte la barra principal A en los miembros laterales del marco y atornille con los pernos M10x35 8.8 (punto 1).
- Los elementos doblados se atornillan a la barra principal A y a la parte inferior de los elementos laterales del marco con pernos M10x35 8.8 (puntos 2 y 3).
- Montar el parachoques.
- Apriete todos los pernos de acuerdo con la configuración de torque: vea la tabla.
- Repare la bola y la placa eléctrica.
- Conecte los cables eléctricos.

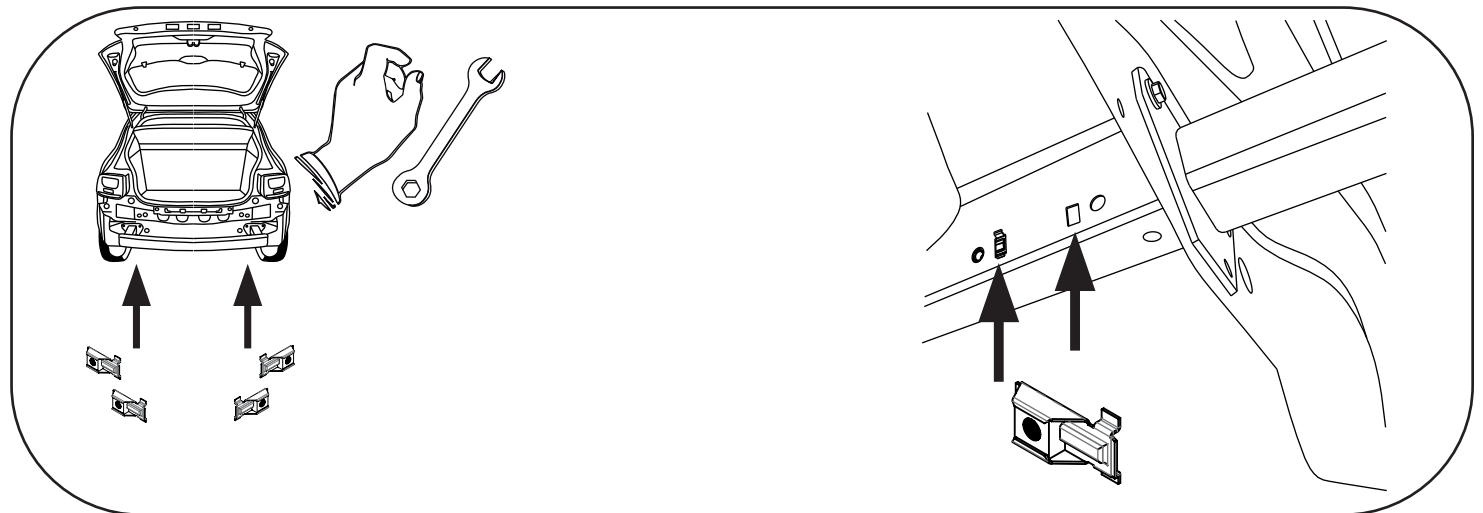
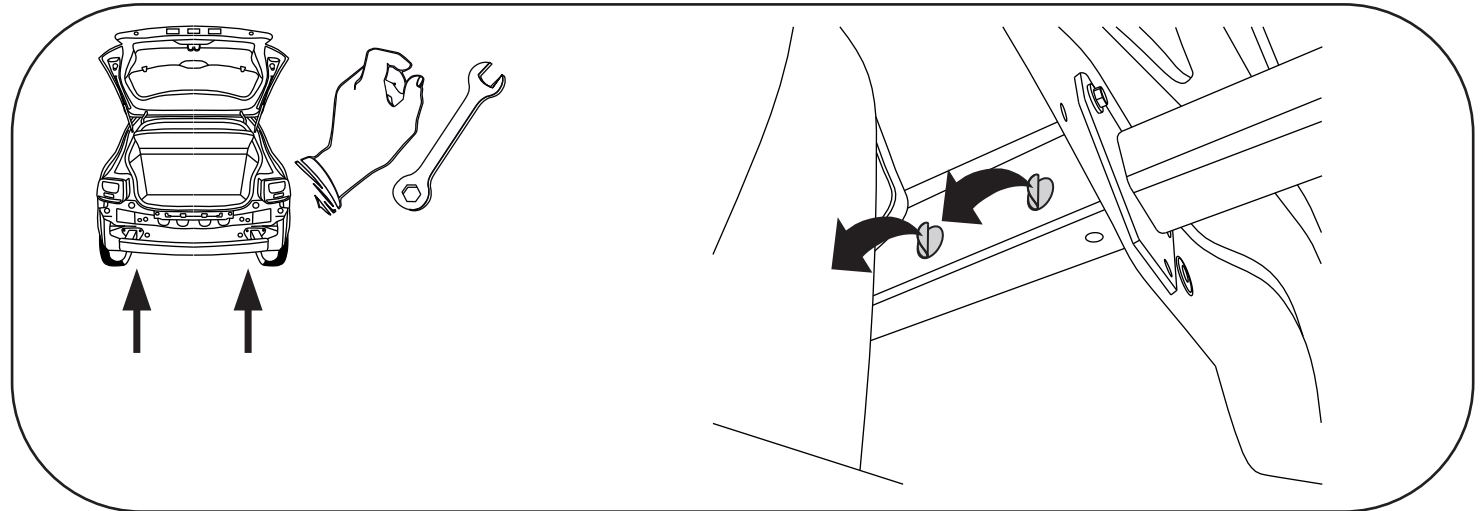
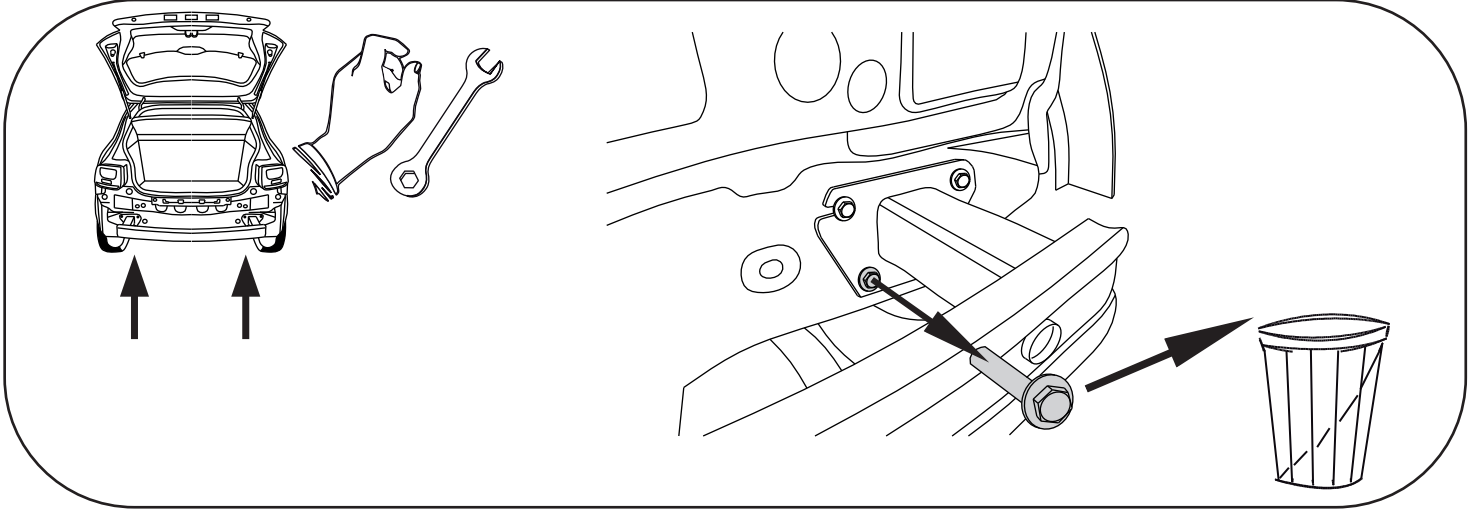
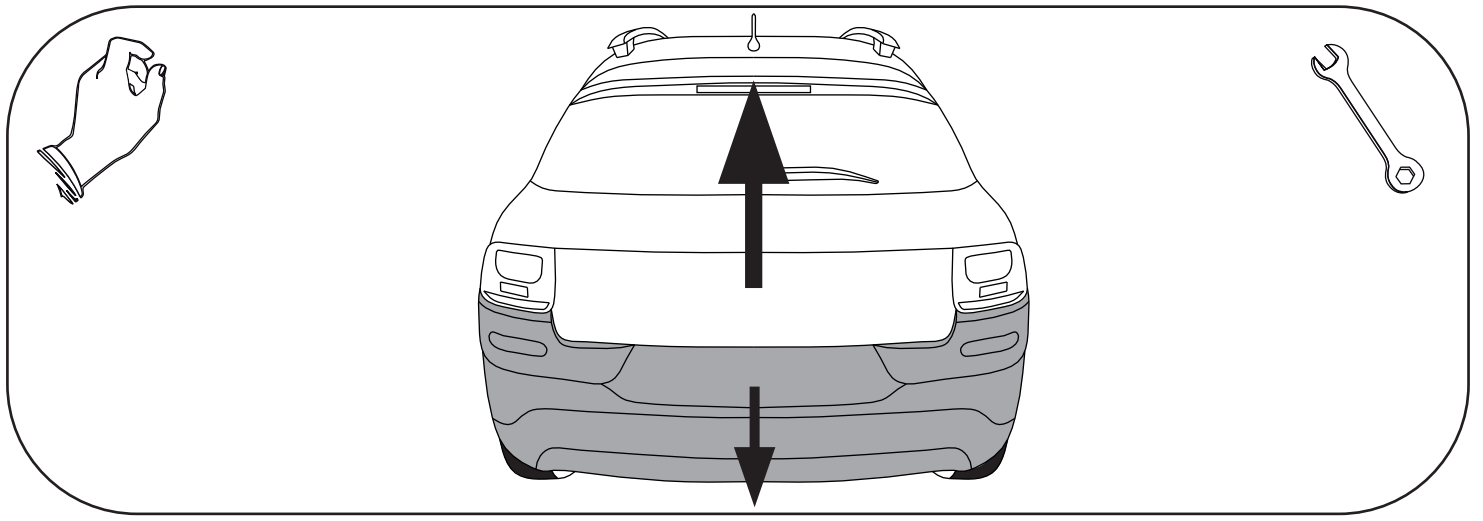

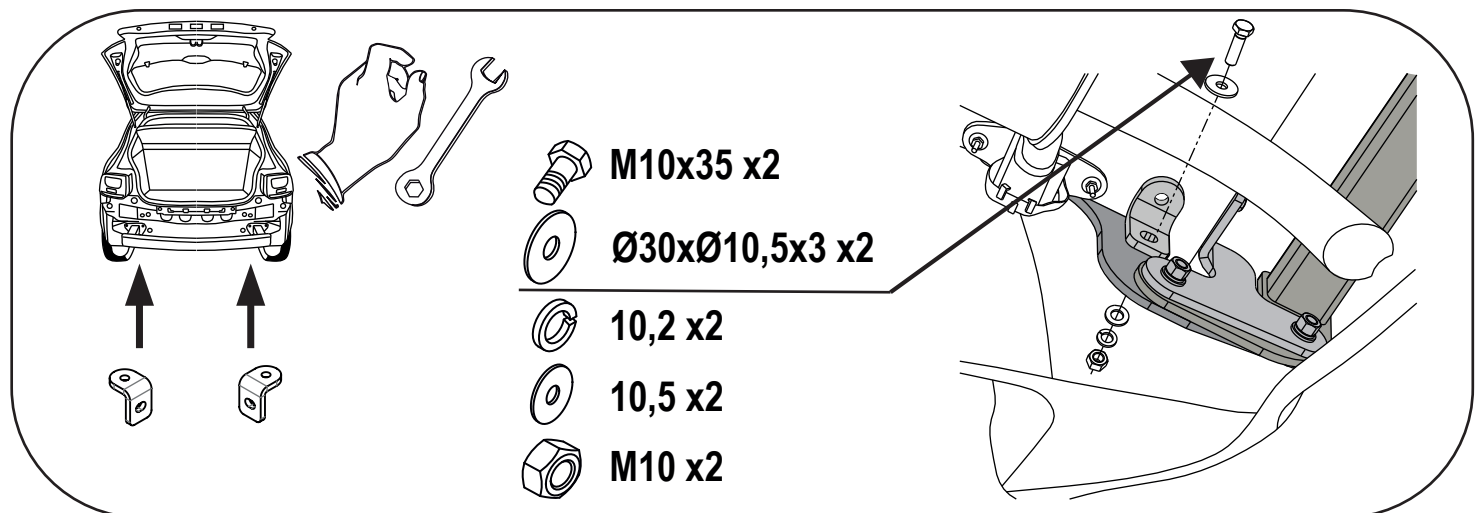
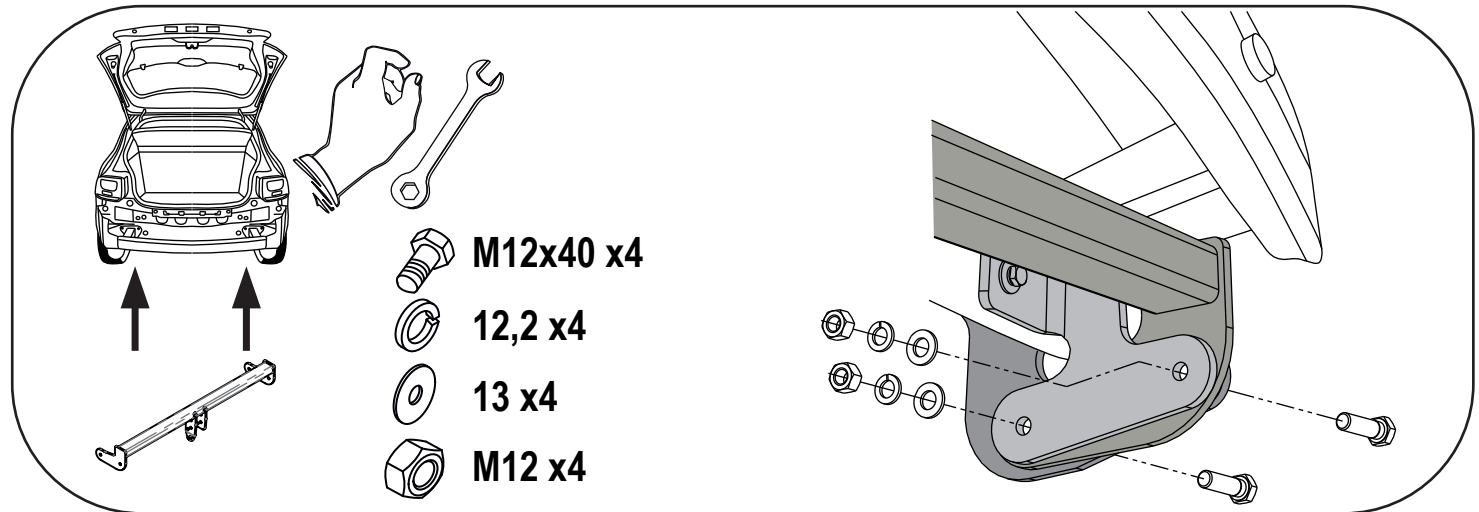
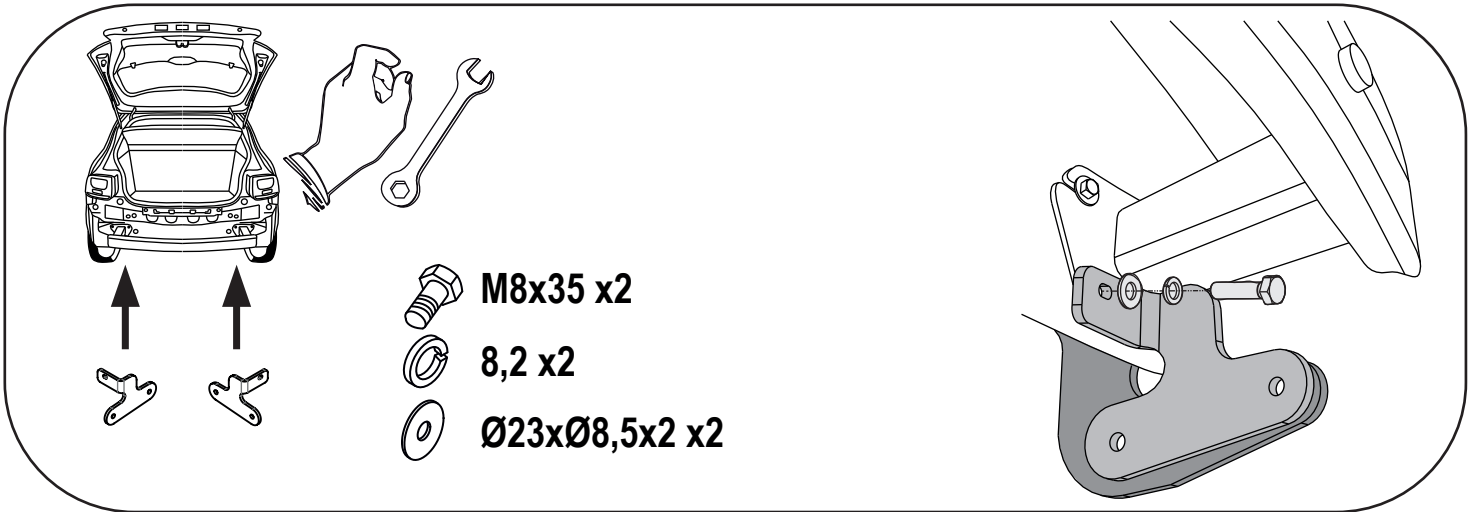
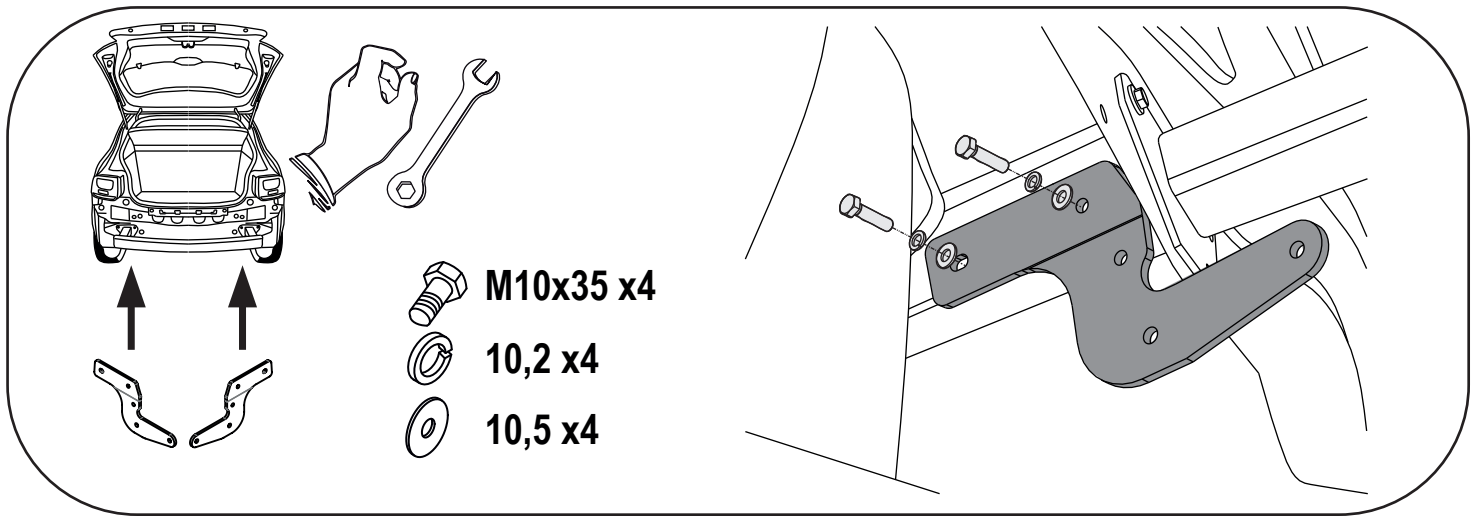

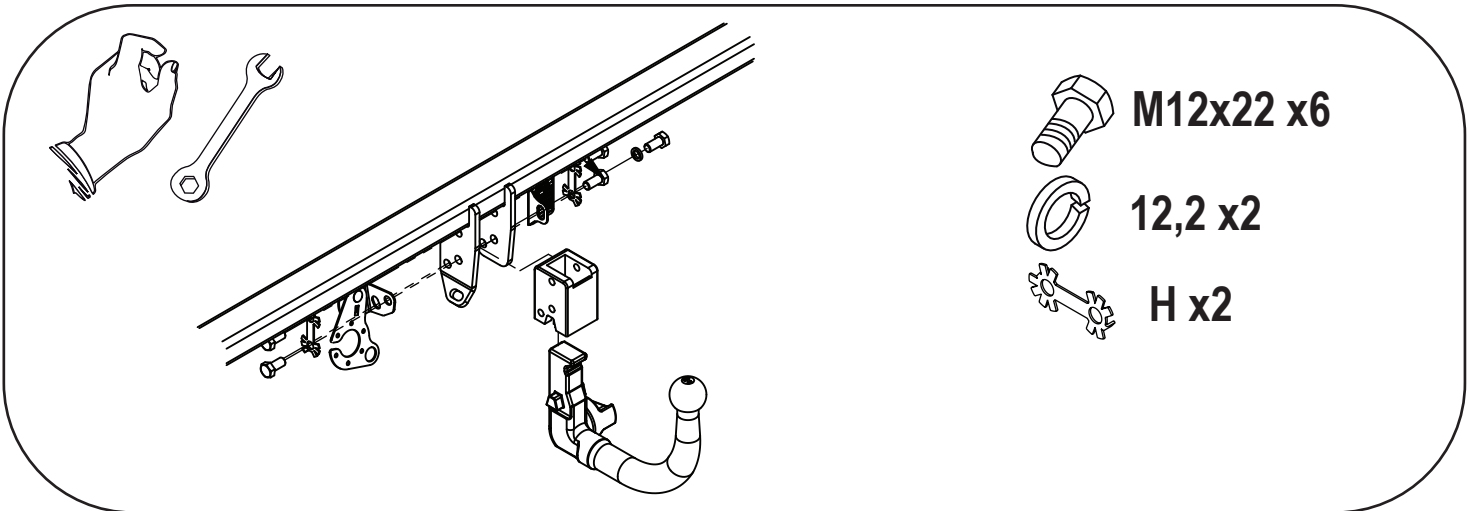
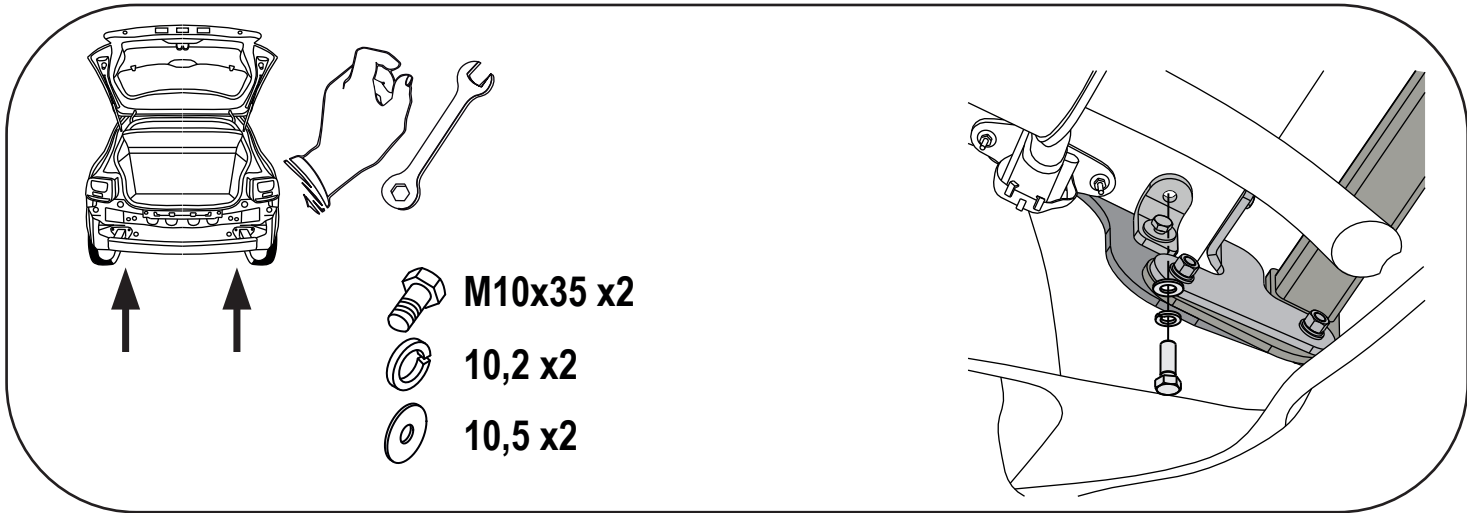





**CRIMP**

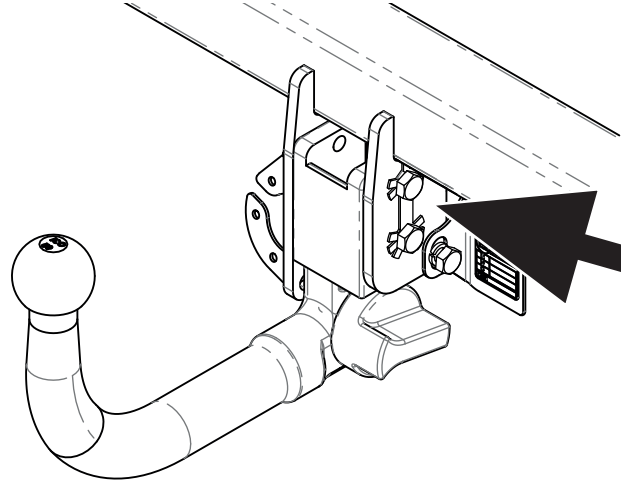
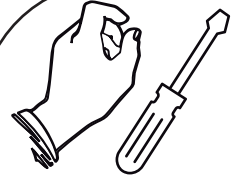
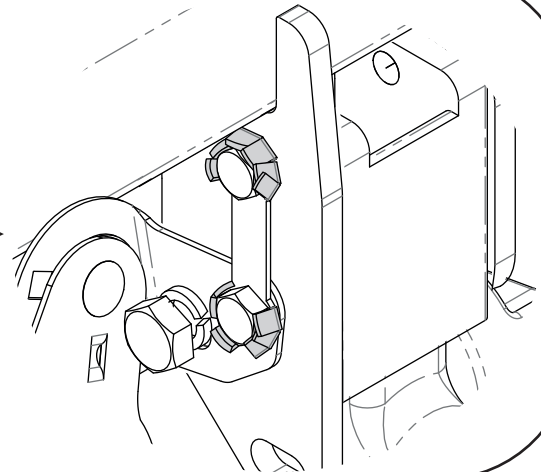
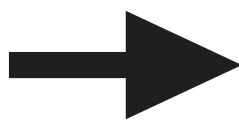
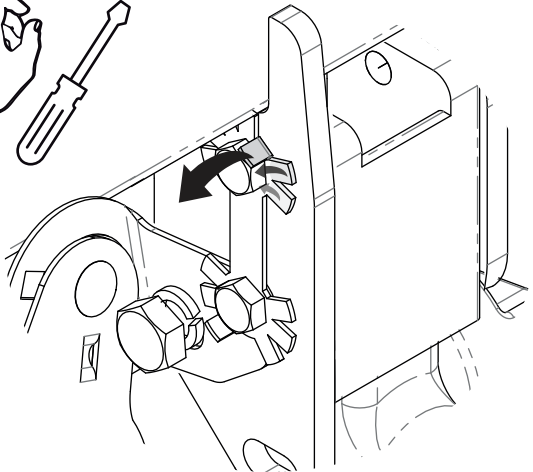
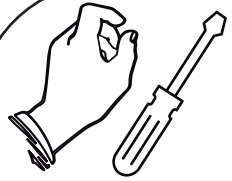
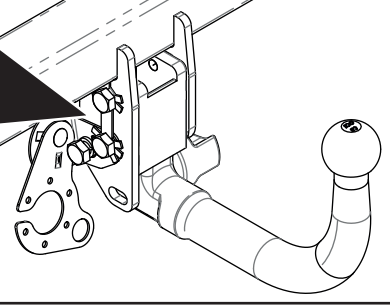

**CRIMP**

