



Cat. No. **W/A31**

VOLKSWAGEN TOUAREG I	10/02-
VOLKSWAGEN TOUAREG II (excl. R-Line)	01/10-
PORSCHE CAYENNE	09/02-

E20

E20 55R-01 3199

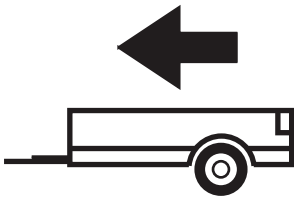

3500kg

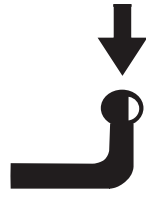

140kg

D=16,40kN

D (kN) =



MAX kg x MAX kg

x 0,00981



MAX kg + MAX kg

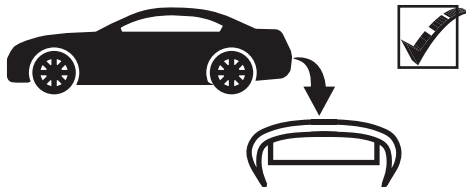

IMIOLA HAK-POL

96-111 KOWIESY, CHOJNATA 23A, POLAND

Tel. + 48 46 831 73 31, fax +48 831 74 29

e-mail: office@imiola.pl, www.imiola.pl

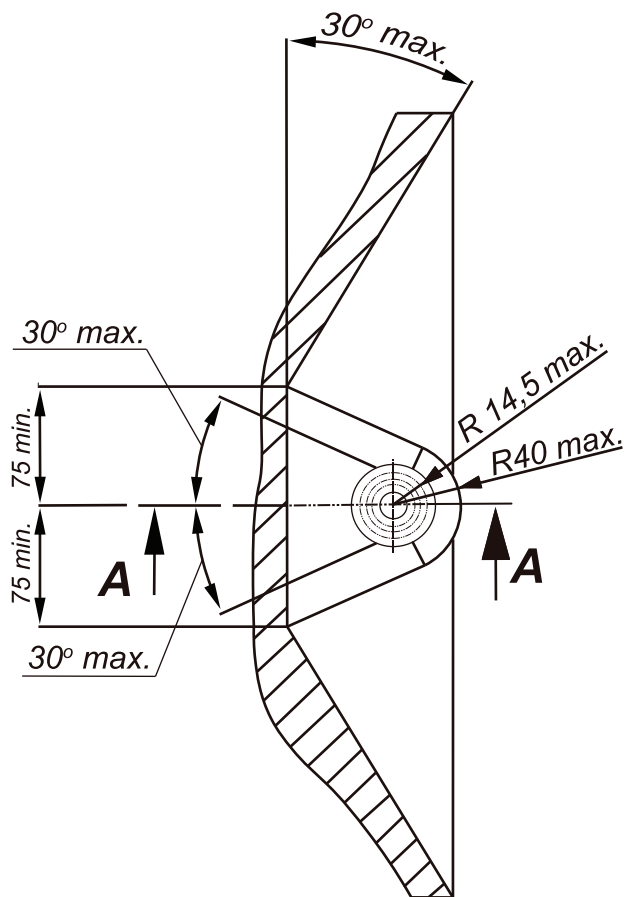

PRZEKRÓJ A-A

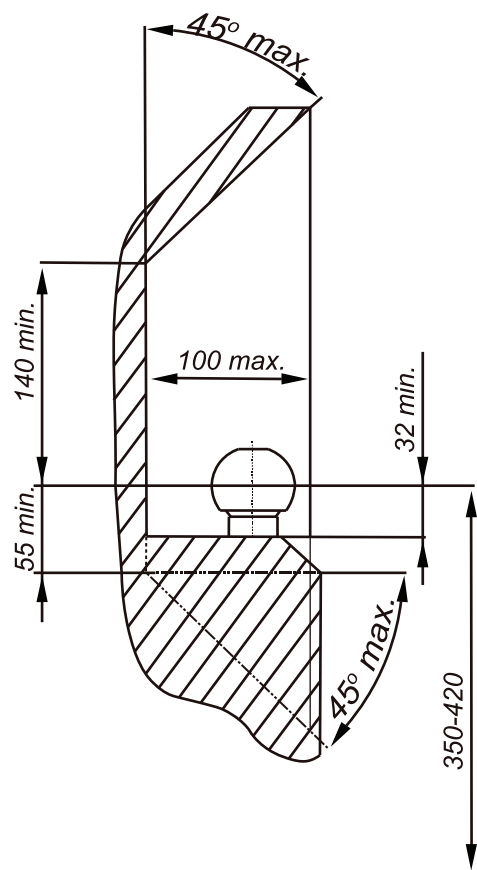

PL Należy zagwarantować przestrzeń swobodną według załącznika VII, rysunek 25a/b Regulaminu EKG ONZ 55.01 przy dopuszczalnym ciężarze całkowitym pojazdu.

F L'espace libre doit être garanti conformément à l'annexe VII, illustration de la réglementation 55.01 CE pour un poids total en charge autorisé du véhicule.

GB The clearance specified in appendix VII, diagram 25a/b of Regulation No. 55.01 UN EU must be guaranteed at laden weight of the vehicle.





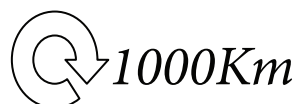

D Der Freiraum nach Anhang VII, Abbildung 25a/b der Vorschriften 55.01 EG ist zu gewährleisten bei zulässigem Gesamtgewicht des Fahrzeuges.

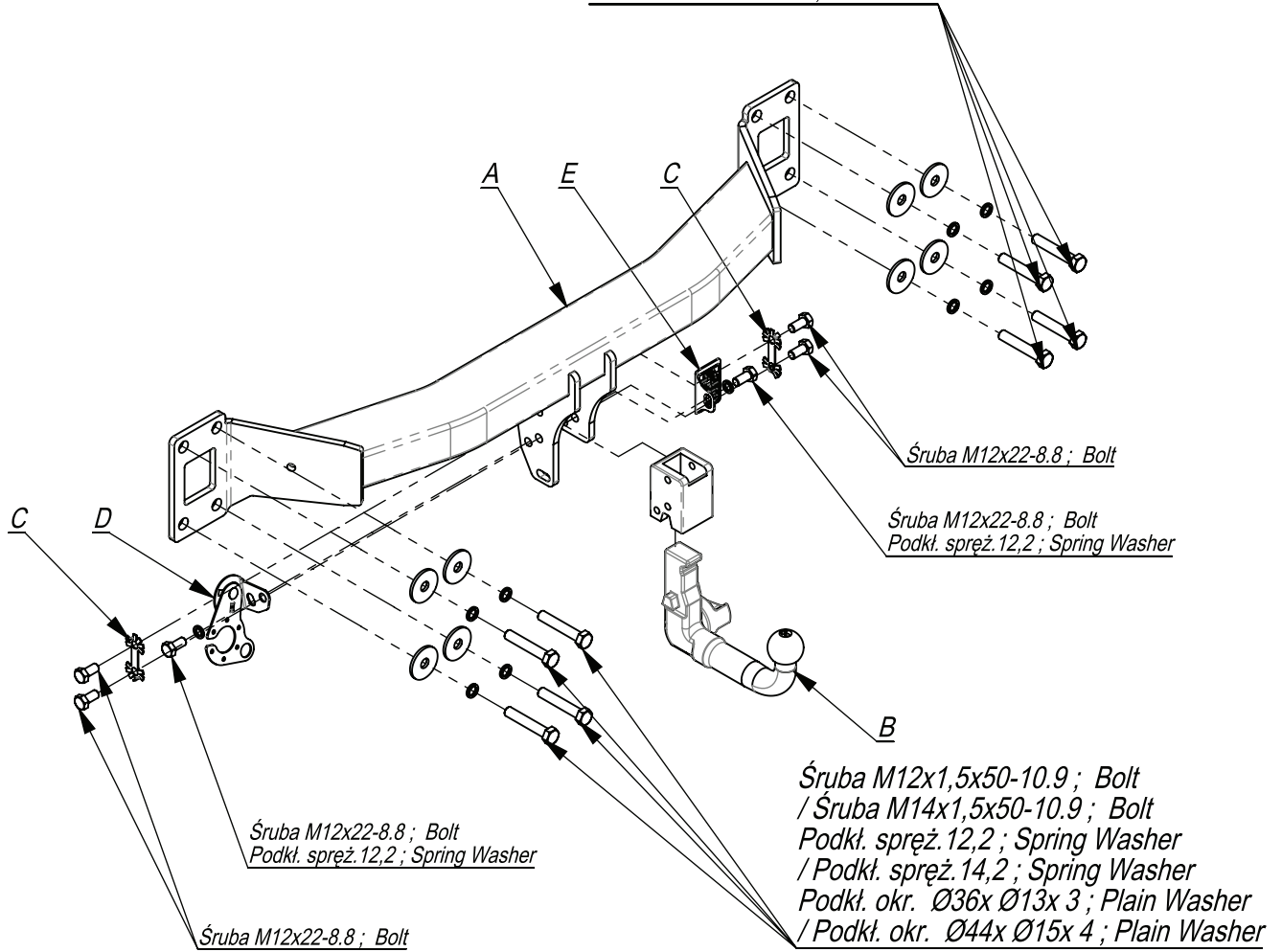
Moment skręcający dla śrub i nakrętek (8.8) Torque settings for nuts and bolts (8.8)	
M8	25Nm
M10	55Nm
M12	85Nm
M14	135Nm
M16	195Nm

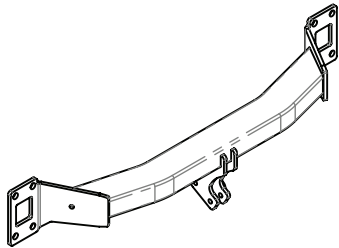
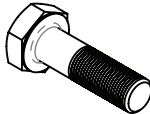
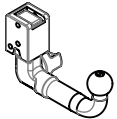

Śruba M12x1,5x50-10.9 ; Bolt
 / Śruba M14x1,5x50-10.9 ; Bolt
 Podkł. spręż. 12,2 ; Spring Washer
 / Podkł. spręż. 14,2 ; Spring Washer
 Podkł. okr. Ø36x Ø13x 3 ; Plain Washer
 / Podkł. okr. Ø44x Ø15x 4 ; Plain Washer



	A	x1		M14x1,5x50	8
				M12x1,5x50	8
				M12x22	6
	B	x1		Ø44x Ø15x 4	8
				Ø36x Ø13x 3	8
	C	x2		14,2	8
				12,2	10
	D	x1			
	E	x1			

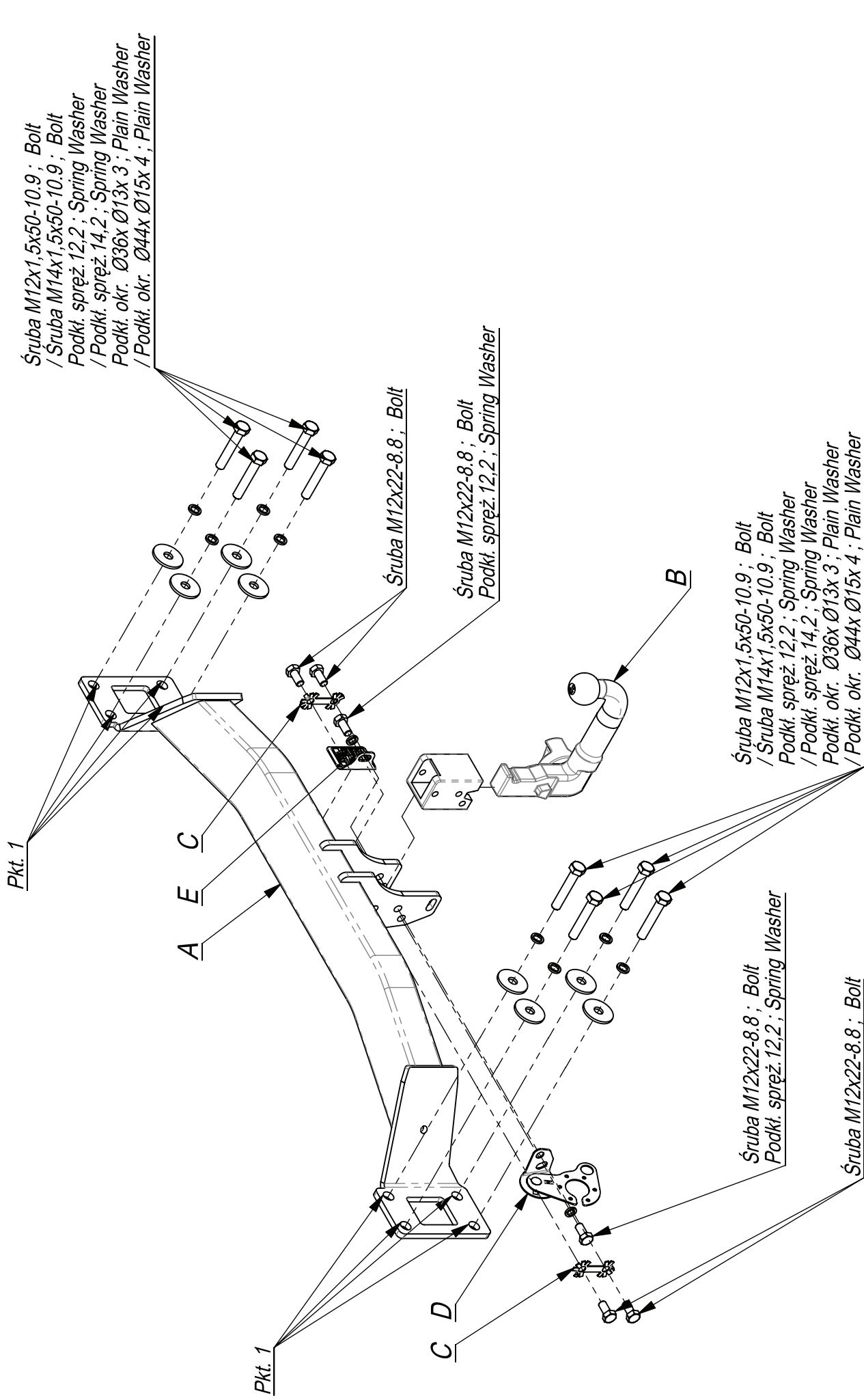

Nr katalogowy **W/A31** Marka **Volkswagen Touareg**
 od 2006/03 ->

96-111 Kowiesy, Chojnata 23 A
 tel. +48 46 831 73 31

- Zdemontować zderzak.
- Odkręcić od tylnego pasa metalowe wzmocnienie zderzaka (nie będzie już wykorzystane).
- Belkę haka A przykręcić do tylnego pasa śrubami M12x50x1,5 lub M14x50x1,5.
- Dokręcić wszystkie śruby z momentem wg tabeli.
- Wykonać wycięcie w dolnej części zderzaka, w jego osi o wymiarach 50x120.
- Przykręcić zderzak.
- Podłączyć instalację elektryczną.
- Przykręcić kulę i blachę gniazda elektrycznego.

- Disassemble the bumper.
- Unscerw the metal reinforcement of the bumper from the rear belt (it will not be used any more).
- Screw the main bar A to the rear belt with bolts M12x50x1,5 or M14x50x1,5.
- Tighten all the bolts according to the torque setting- see the table.
- Cut out the fragment 50x120 in the lower part of the bumper, in its axle.
- Screw the bumper.
- Connect the electric wires.
- Fix the ball and electric plate.

- Démonter le pare-chocs.
- Dévisser le renforcement en métal de la jupe arrière (il ne sera plus utilisé).
- Visser la poutre du crochet A à la jupe arrière à l'aide des boulons M12x50x1,5 ou M14x50x1,5.
- Serrer tous les boulons avec un couple de serrage selon tableau.
- Dans la partie inférieure du pare-chocs, dans son axe, couper un fragment aux dimensions 50x120.
- Monter le pare-chocs.
- Raccorder le circuit électrique.
- Visser le crochet d'attelage et socle de prise électrique.

- Die Stoßstange demontieren.
- Von dem hinteren Karosseriestreifen die Metallverstärkung der Stoßstange abschrauben (wird nicht wieder gebraucht).
- Den Querbalken A an den hinteren Karosseriestreifen mit den Schrauben M12x50x1,5 oder M14x50x1,5 anschrauben.
- Alle Schrauben mit dem in der Tabelle angegebenen Drehmoment festschrauben.
- Einen Ausschnitt in unterem Teil der Stoßstange, in ihrer Achse 50x120 ausführen.
- Die Stoßstange anschrauben.
- Die Elektroinstallation anschließen.
- Die Kugel und die Steckdosenhalterung anschrauben.

- Desenroscar el parachoques.
- Desenroscar el realzar del parachoques (ya no se montará).
- Colocar la barra del gancho A al latón trasero y apretar con las tuercas M12x50x1,5 o M14x50x1,5.
- Cortar la parte inferior del parachoques en sue je, un pedazo de 120x50
- Instalar el parachoques.
- Apretar la bola y la placa de la toma de corriente tornillos M12x70 8.8. (p. 2).
- Apretar todos los tornillos con el par según la tabla anterior.
- Conectar la instalación eléctrica..

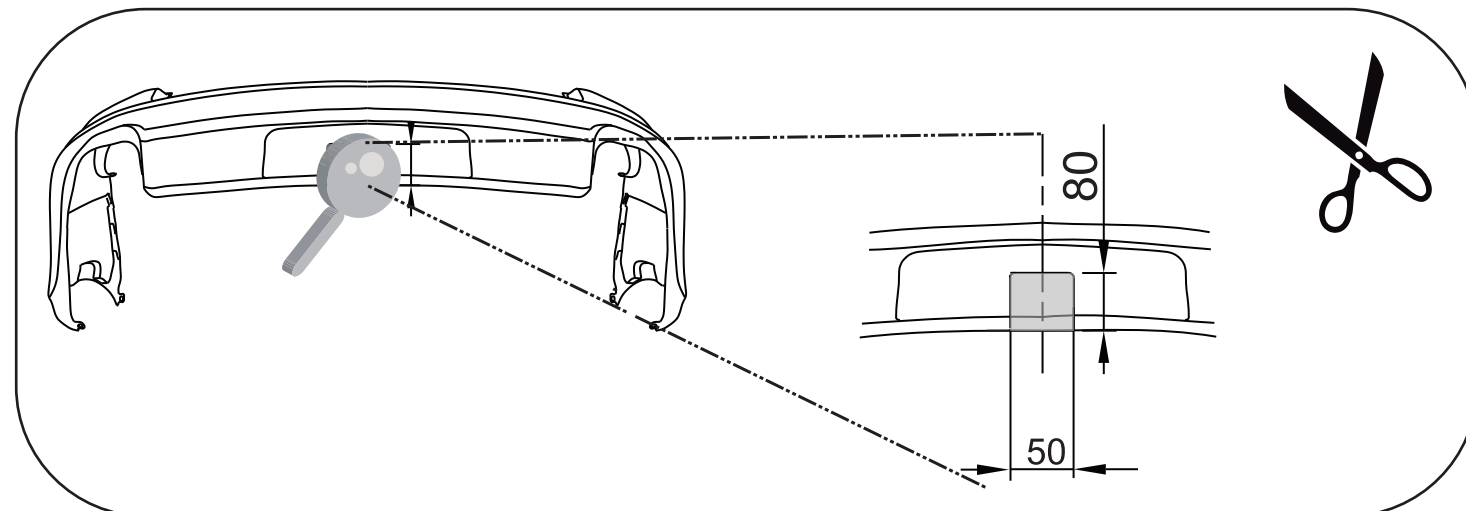
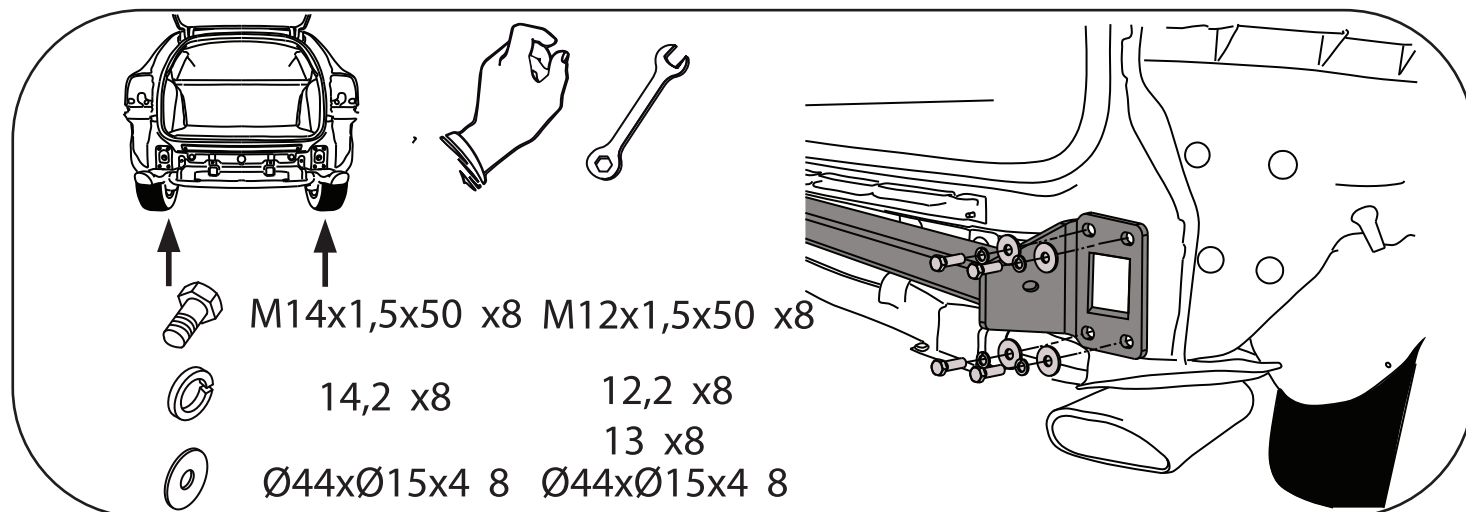
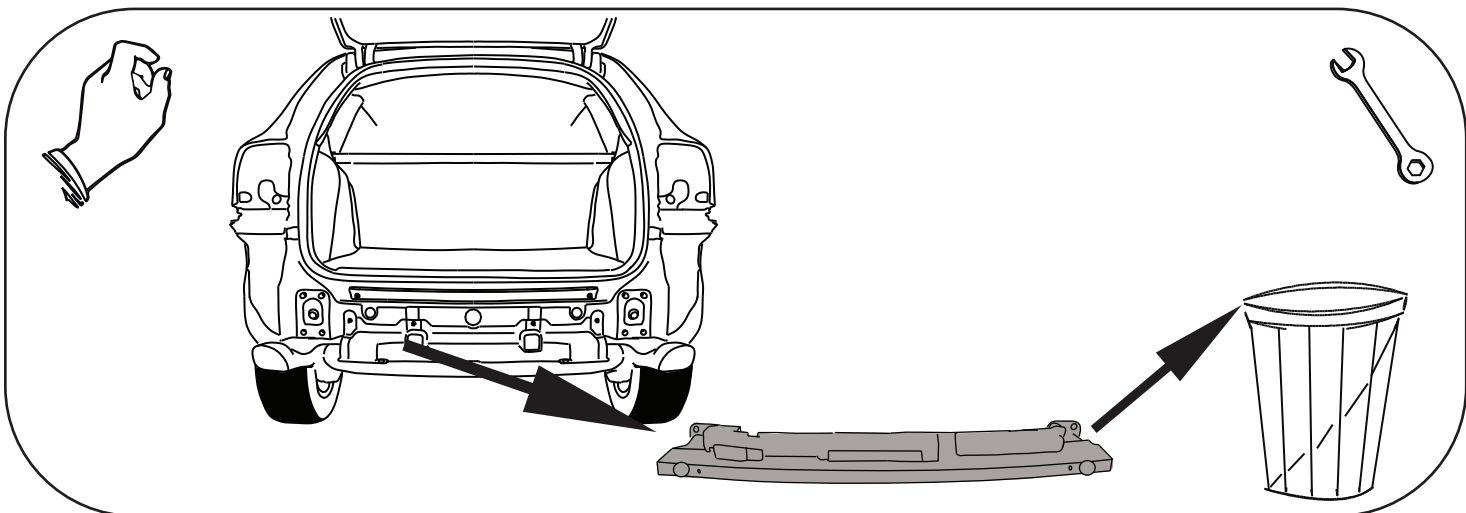
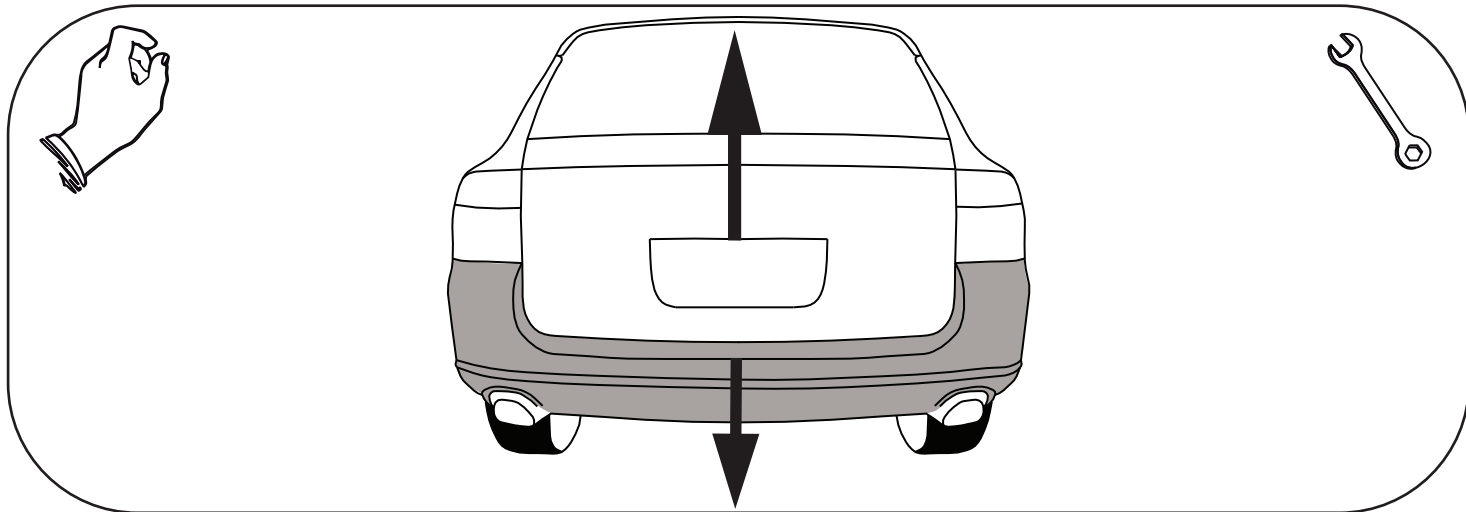

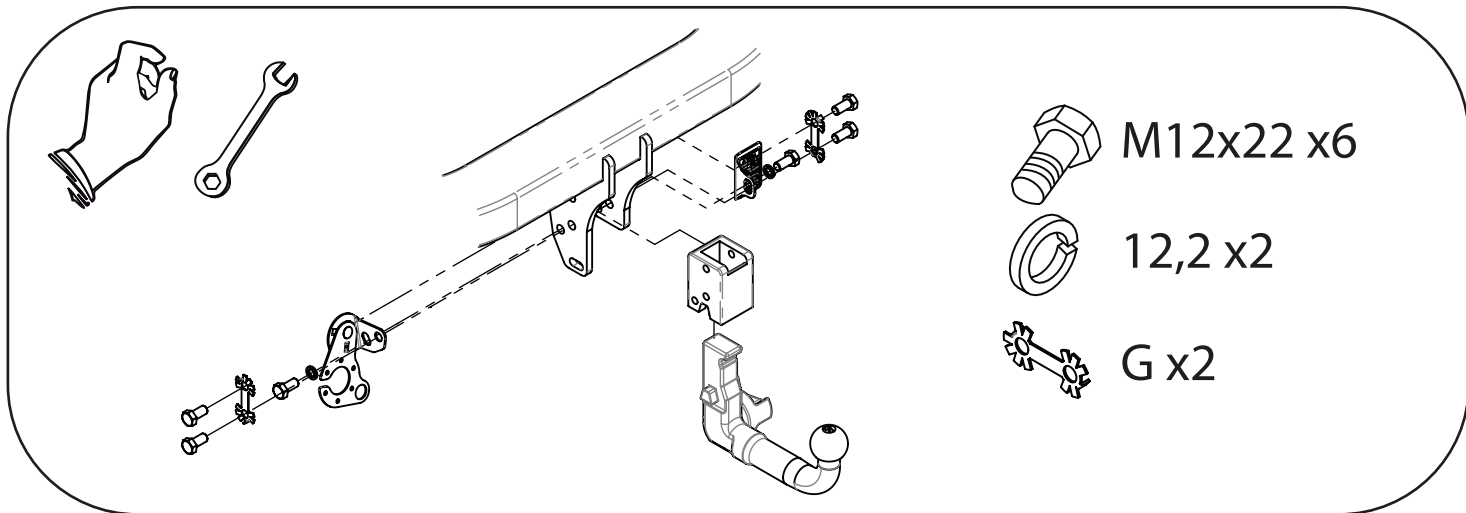
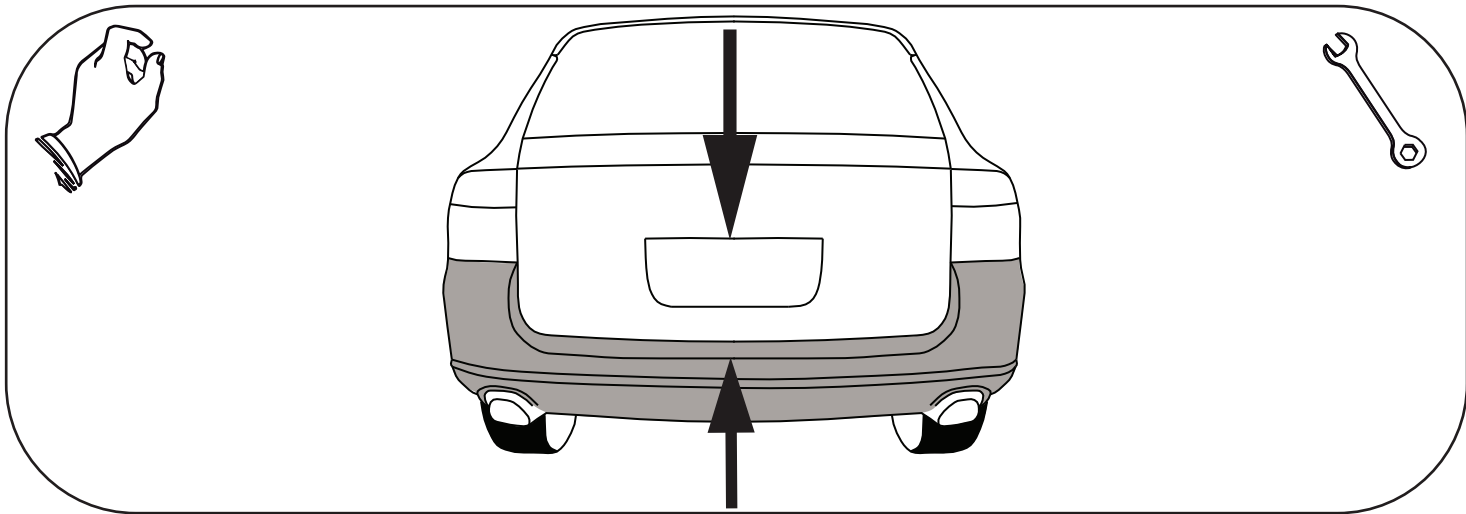



CRIMP

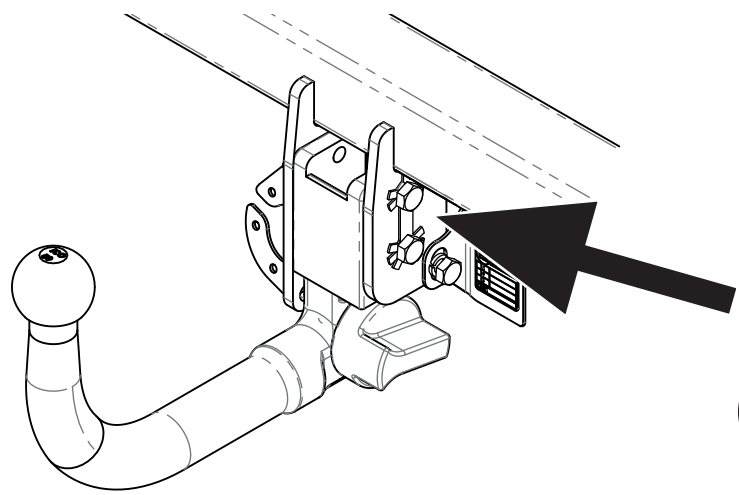
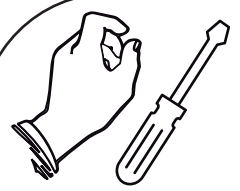
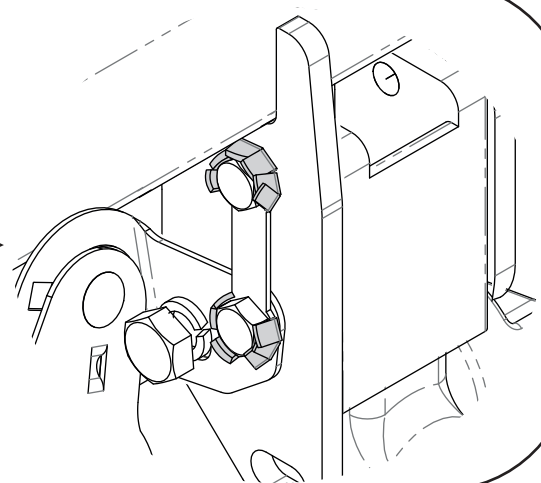
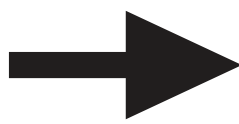
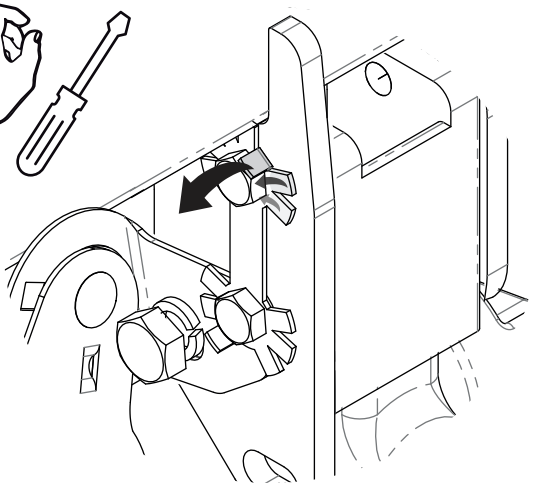
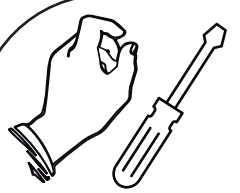
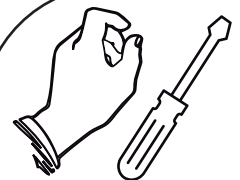
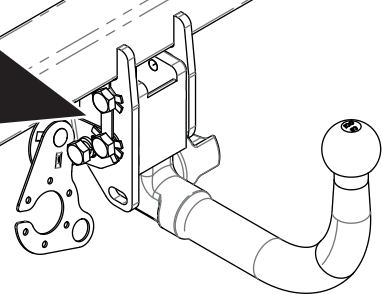

CRIMP

