



MAZDA
CX-5 excl. ADBLUE

2017 -

Cat. No. X/A31

E20

E20 55R-01 5406

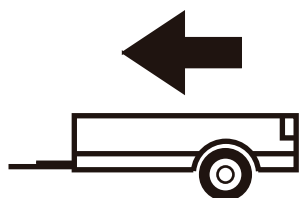

2100kg

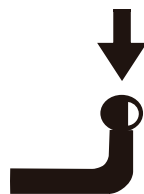

100kg

D = 10,40kN

D (kN) =



MAX kg

x

MAX kg

x 0,00981



MAX kg

+

MAX kg

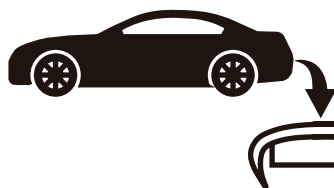

IMIOLA HAK-POL

96-111 KOWIESY, CHOJNATA 23A, POLAND

Tel. + 48 46 831 73 31, fax +48 831 74 29

e-mail: office@imiola.pl, www.imiola.pl

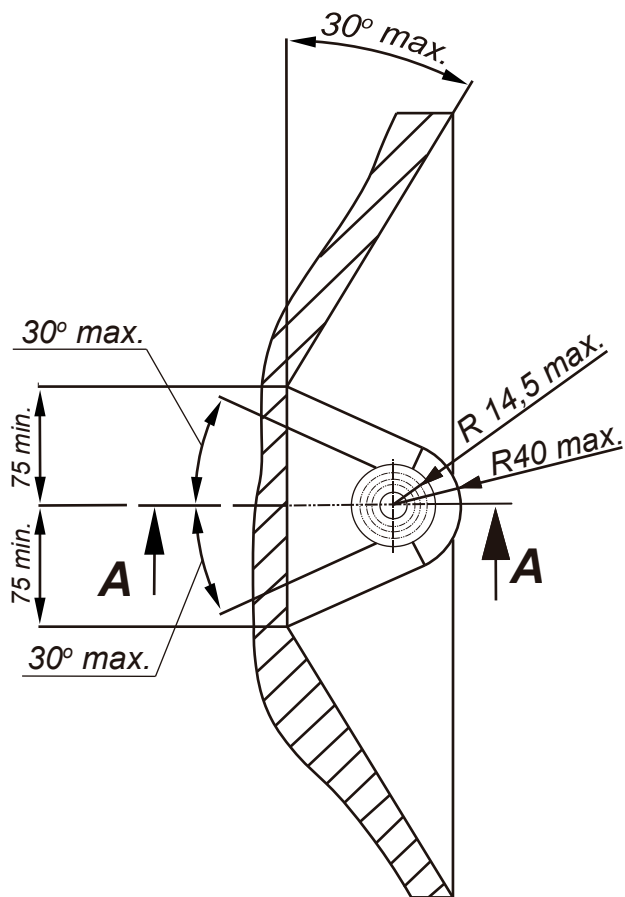

PRZEKRÓJ A-A

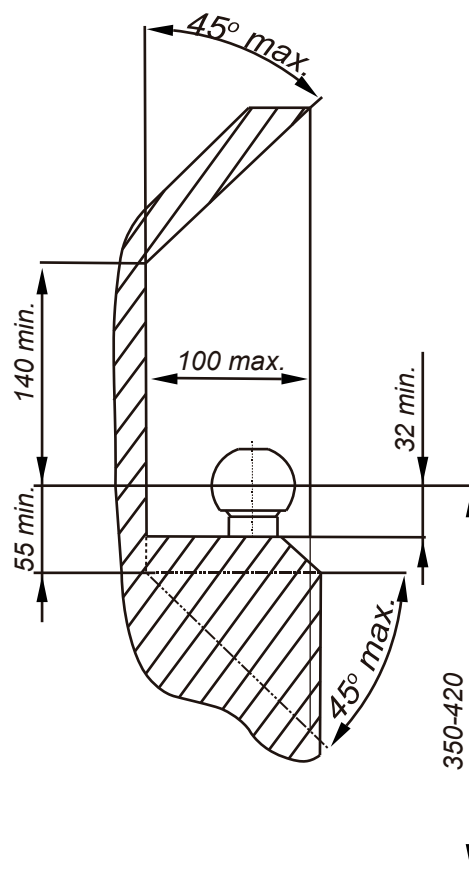

PL Należy zagwarantować przestrzeń swobodną według załącznika VII, rysunek 25a/b Regulaminu EKG ONZ 55.01 przy dopuszczalnym ciężarze całkowitym pojazdu.

F L'espace libre doit être garanti conformément à l'annexe VII, illustration de la réglementation 55.01 CE pour un poids total en charge autorisé du véhicule.

GB The clearance specified in appendix VII, diagram 25a/b of Regulation No. 55.01 UN EU must be guaranteed at laden weight of the vehicle.

D Der Freiraum nach Anhang VII, Abbildung 25a/b der Vorschriften 55.01 EG ist zu gewährleisten bei zulässigem Gesamtgewicht des Fahrzeuges.

Moment skrecający dla śrub i nakrętek (8.8) Torque settings for nuts and bolts (8.8)

M8	25Nm
M10	55Nm
M12	85Nm
M14	135Nm
M16	195Nm

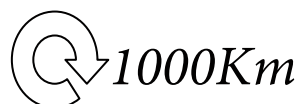

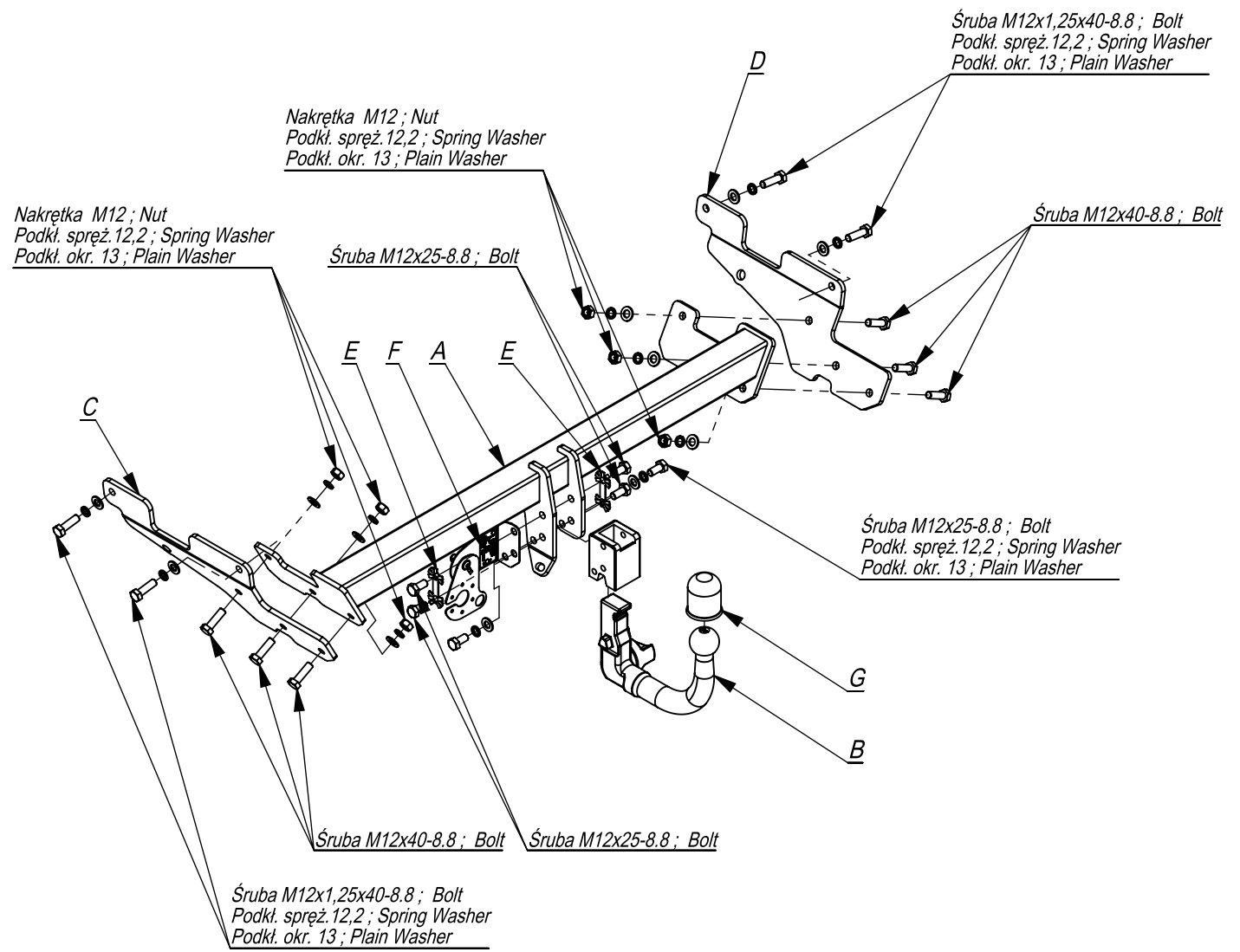

	A	x1		M12x1,25x40	4
				M12x40	6
				M12x25	6
	B	x1		M12	6
	C	x1		13	10
	D	x1		12,2	12
	E	x2			
	F	x1			
	G	x1			

Śruba M12x1,25x40-8.8 ; Bolt
 Podkl. spręż. 12,2 ; Spring Washer
 Podkl. okr. 13 ; Plain Washer

Pkt. 1

Pkt. 2

Śruba M12x40-8.8 ; Bolt

D

Śruba M12x25-8.8 ; Bolt
 Podkl. spręż. 12,2 ; Spring Washer
 Podkl. okr. 13 ; Plain Washer

Pkt. 3

Nakrętka M12 ; Nut
 Podkl. spręż. 12,2 ; Spring Washer
 Podkl. okr. 13 ; Plain Washer

Śruba M12x25-8.8 ; Bolt

E F A E

Śruba M12x25-8.8 ; Bolt
 Podkl. spręż. 12,2 ; Spring Washer
 Podkl. okr. 13 ; Plain Washer

Śruba M12x25-8.8 ; Bolt

Nakrętka M12 ; Nut
 Podkl. spręż. 12,2 ; Spring Washer
 Podkl. okr. 13 ; Plain Washer

C

Pkt. 2

Śruba M12x1,25x40-8.8 ; Bolt
 Podkl. spręż. 12,2 ; Spring Washer
 Podkl. okr. 13 ; Plain Washer

Pkt. 3

Śruba M12x40-8.8 ; Bolt

G

B



Nr katalogowy Marka

96-111 Kowiesy, Chojnata 23 A
 tel. +48 46 831 73 31

X/A31 Mazda CX-5 od 2017 ->

- Odkręcić zderzak i tylne lampy.
- Elementy haka C i D poprzez technologiczne otwory przykręcić do podłużnic śrubami M12x1.25x40 8.8 (pkt 1,2).
- Do elementów C i D przykręcić belkę haka A śrubami M12x40 8.8 (pkt 3).
- Dokręcić wszystkie śruby z momentem wg tabeli.
- Zamontować zderzak, lampy.
- Przykręcić kulę i blachę gniazda elektrycznego.
- Podłączyć instalację elektryczną.

- Unscrew the bumper and rear lamps.
- Screw the elements C and D to the frame side members through the technological holes with bolts M12x1,25x40 8.8 (point 1 and 2).
- Screw the main bar A to the elements C and D with bolts M12x40 8.8 (point 3).
- Tighten all the bolts according to the torque setting- see the table.
- Assemble the bumper and lamps.
- Fix the ball and electric plate.
- Connect the electric wires.

- Dévissez les lampes, le pare-chocs.
- Les éléments à crochets C et D doivent être vissés sur les longerons à l'aide de boulons M12x1,25x40 8.8 (point 1 et 2).
- Pour les éléments C et D, fixer l'attelage A avec les boulons M12x40 8.8. (point 3).
- Serrer tous les boulons avec un couple de serrage selon tableau.
- Installer le pare-chocs et les lampes.
- Brancher l'installation électrique. Visser la boule et la tôle de la prise électrique.

- Die Rückleuchten und die Stoßstange abschrauben.
- Die AHK-Bauteile C und D mit Schrauben M12x1,25x40 8.8 an den Längsträgern festschrauben (Punkt 1 und 2).
- Den AHK-Querträger A an die Bauteile C und D mit Schrauben M12x40 8.8 anschrauben (Punkt 3).
- Ziehen Sie alle Schrauben mit dem Drehmoment gemäß der Tabelle an.
- Den Stoßfänger und die Rückleuchten einbauen.
- Die elektrische Installation anschließen.
- Die AHK-Kugel und die Steckdosenplatte festziehen.

- Desenrosque las lámparas y el parachoques.
- Fijar los elementos C y D del gancho a los largueros con tornillos M12x1,25x40, 8.8 (punto 1 y 2).
- Atornillar la viga de la bola de remolque A a los elementos C y D usando tornillos M12x40 8.8 (punto 3).
- Apretar todos los tornillos con el par según la tabla anterior.
- Montar el parachoques y las luces.
- Apretar la bola y la placa de la toma eléctrica.
- Conectar la instalación eléctrica.

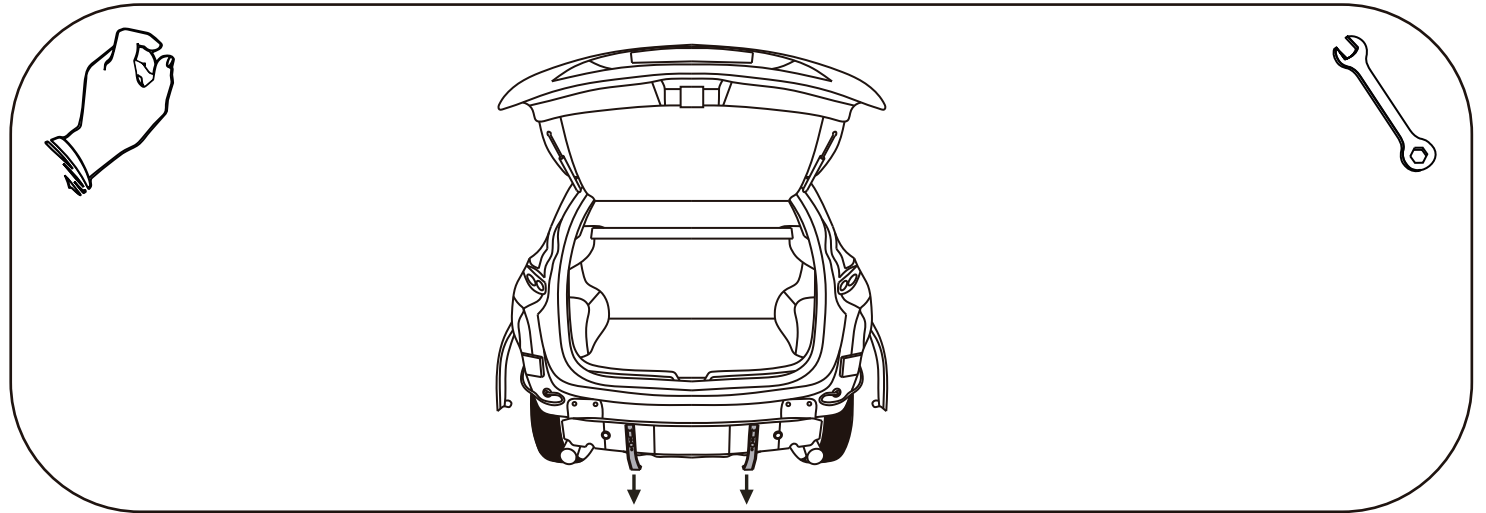
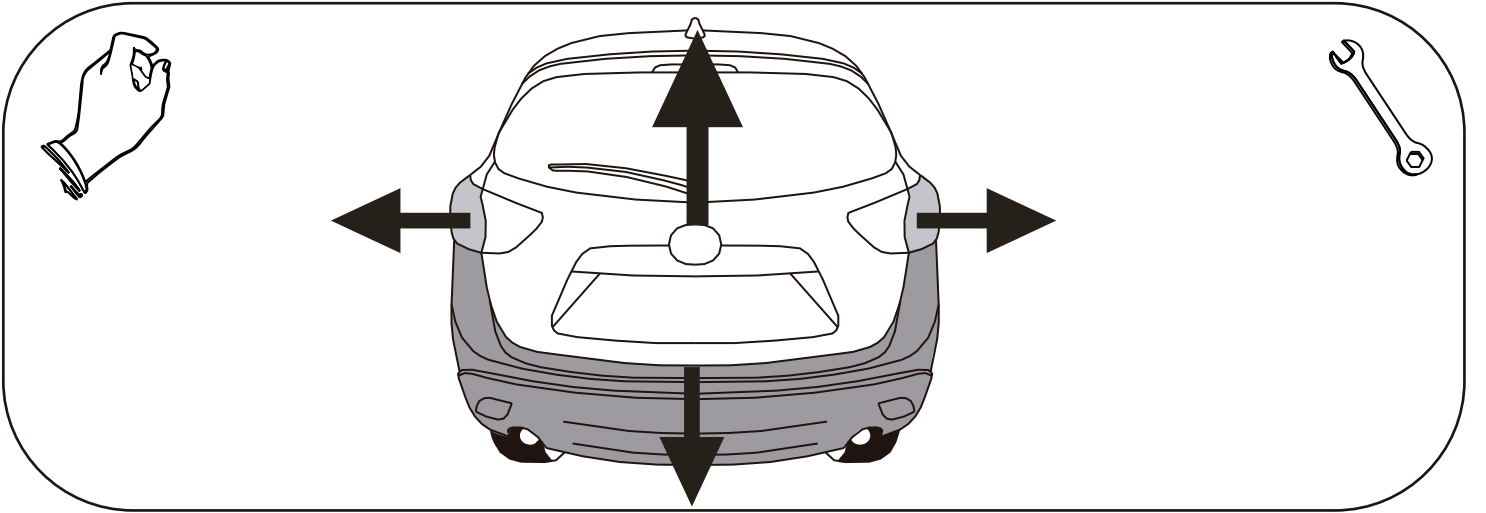

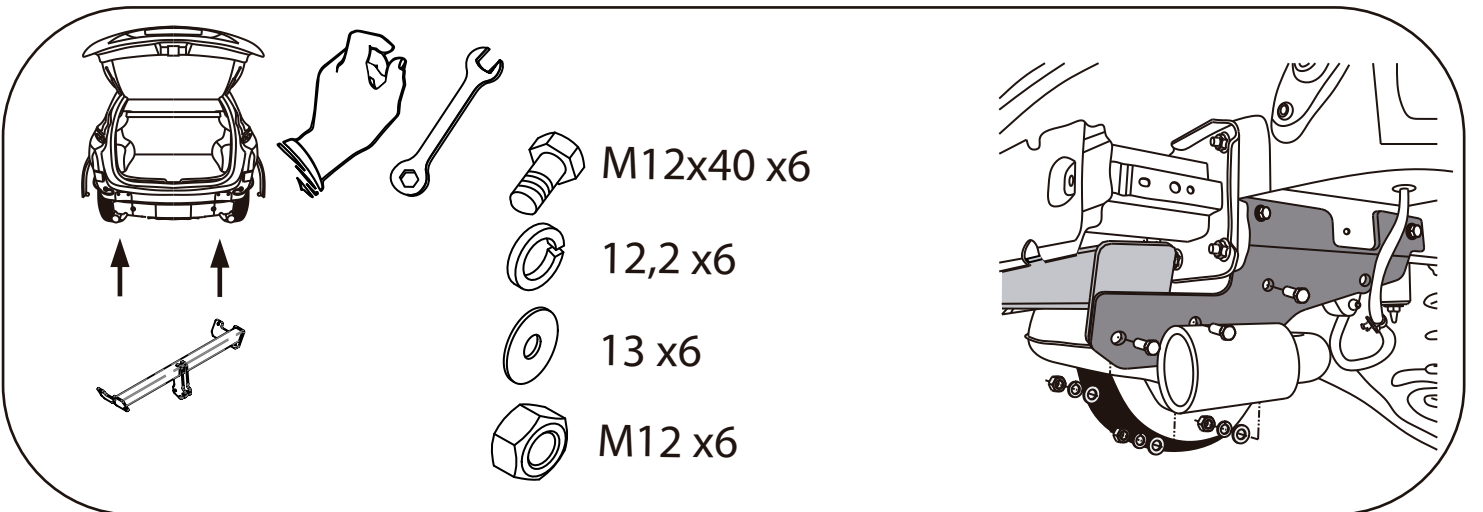
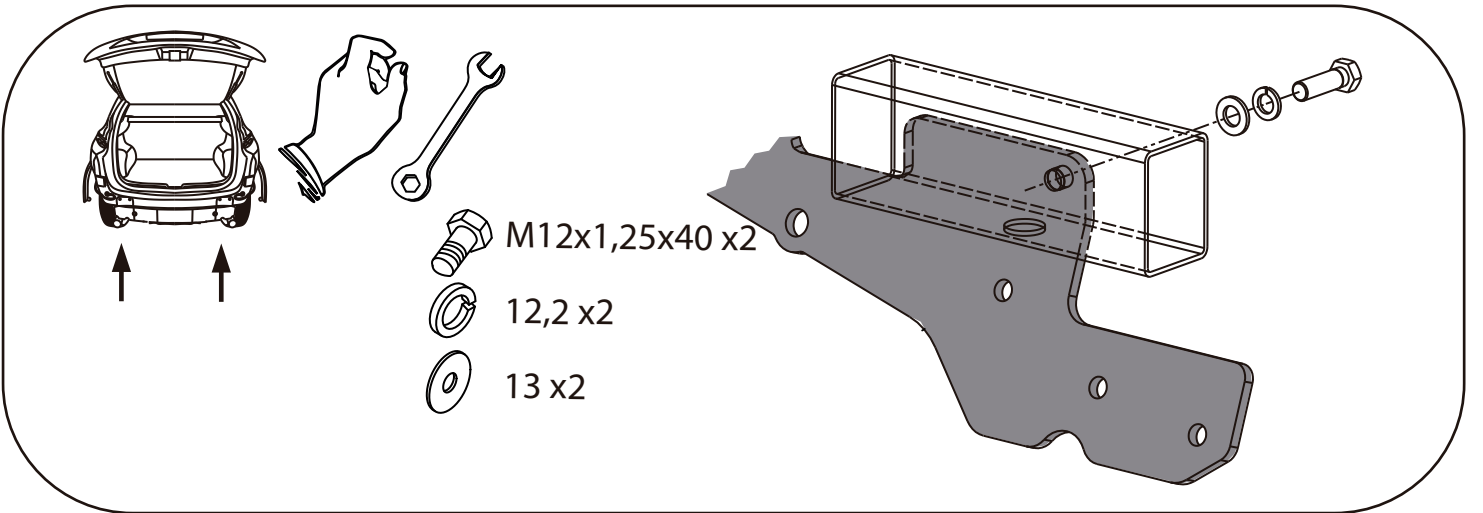
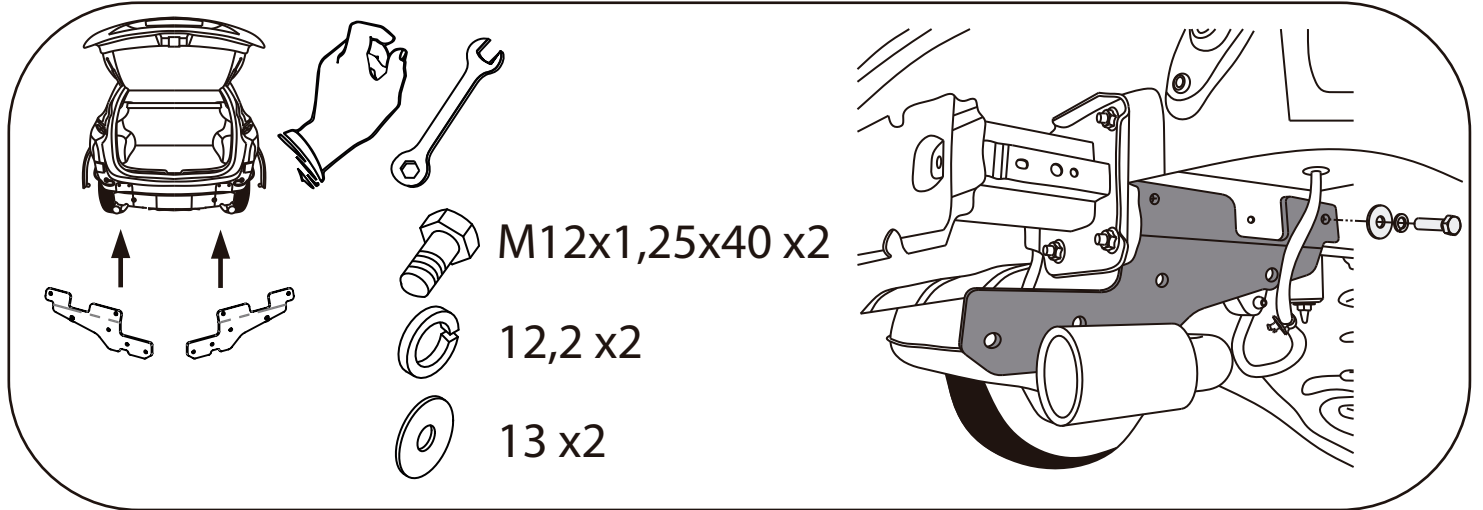

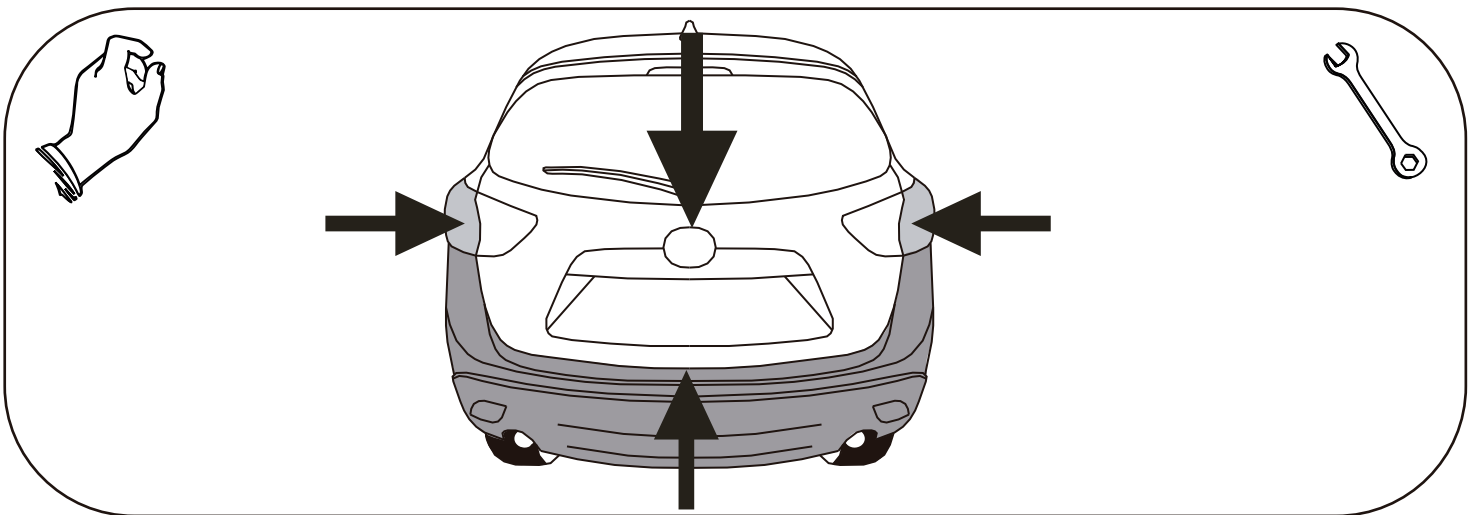
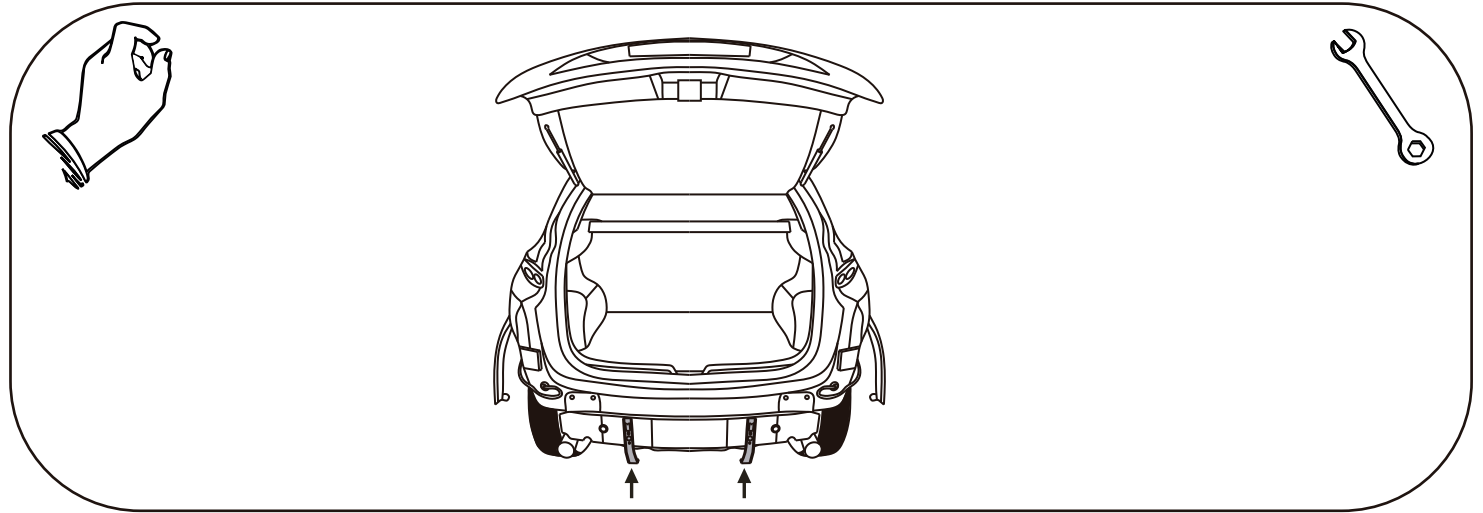
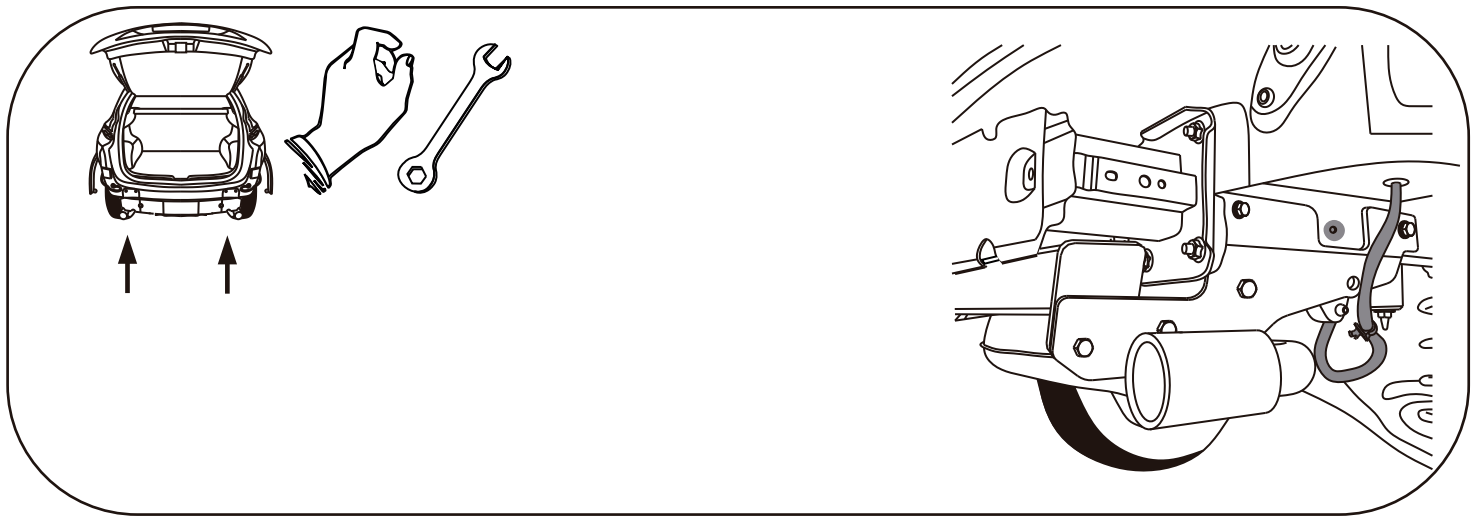

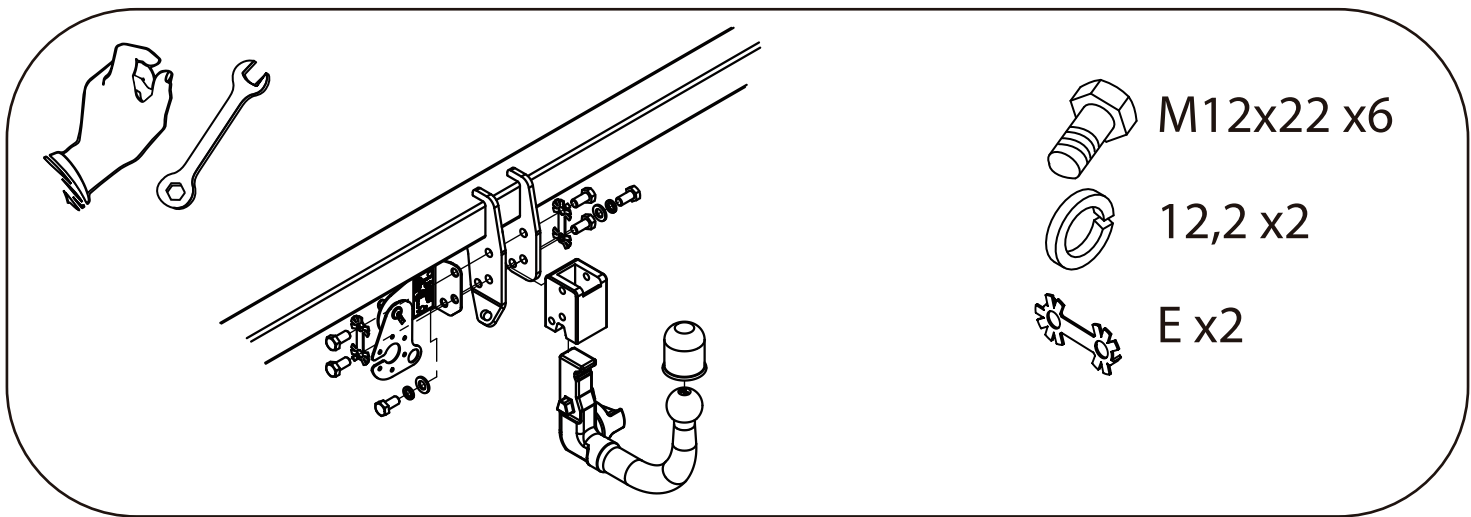

M12x22 x6



12,2 x2

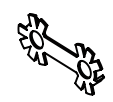

E x2